



System Technology, Inc's Case Shaker is an automatic system designed to settle and produce a uniform distribution of bulk fill product and allow for efficient compaction of a case in minimum time. The case shaker is fully adjustable to settle and compact a wide range of cases and can be fully integrated into any system. Mild or 304 stainless steel offers a sanitary heavy duty design for a rugged and sturdy build and is ideal for food applications as well as bread and bakery products, frozen foods, pharmaceuticals, powder and granule items, fasteners, and weigh & filing systems.

CASE SHAKER

20655 AMHERST COURT, JOLIET, IL
P: 815.726.6700 F: 815.726.6740



WWW.SYSTEMTECHNOLOGYINC.COM
INFO@SYSTEMTECHNOLOGYINC.COM



System Technology, Inc.

Standard Features

- Sanitary Design Ideal for Food Application
- Heavy Duty Tubular & Formed Steel Construction
- Adjustable Case Centering Device
- Standard Height Range Adjustable $\pm 6''$
- Stand Alone Unit or Complete System Integration
- Controls
- Unattended Operation
- Mild Steel Grey Powder Coat Finish

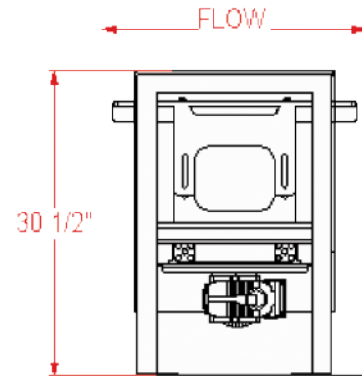

Optional Features

- 304 Stainless Steel Construction
- Additional Powder Coat Finishes Available
- Customized Height
- Multi-Case Count Settling
- Conveyor Optional
- Additional Customization Upon Request

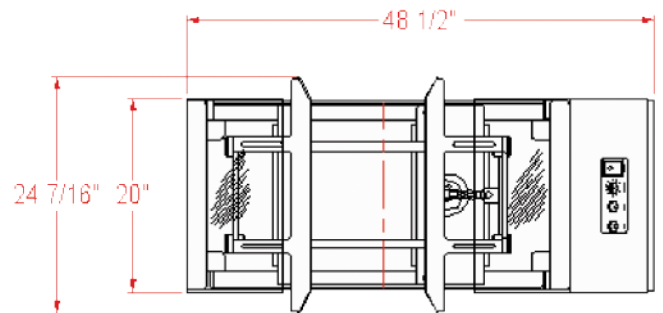

Specifications:

Electrical	100V, 1-Phase, 60Hz Std.
Pneumatic	5 SCFM @ 80 PSI
Erected Case Size	
Length	9" - 30"
Width*	10 $\frac{1}{32}$ " - 24 $\frac{1}{4}$ "
Height	24"
Product Rate	Varies
*width dependent on model	

